

	Base Radius (mm)	CX	CC	Irregularity (fringes)	Clear Aperture (mm)	Surface Quality (typical)	Centration (arcmin)
R1	7.570	X		1.0	6.5	40/20	3
R2	110.31		X	1.0	6.0	40/20	

REVISIONS			
REV.	DESCRIPTION	DATE	APPROVED
D	Updates	8/21/2019	DF

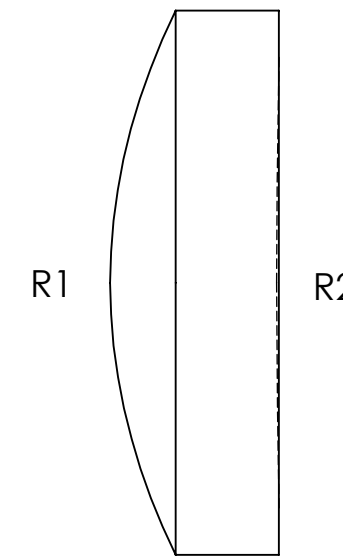
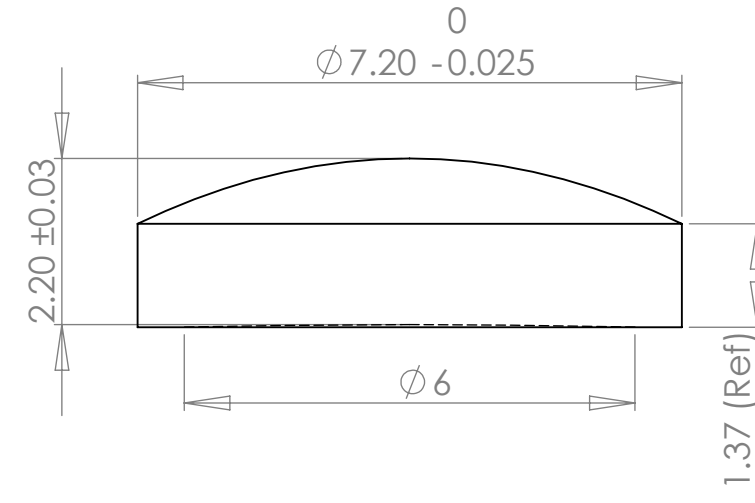
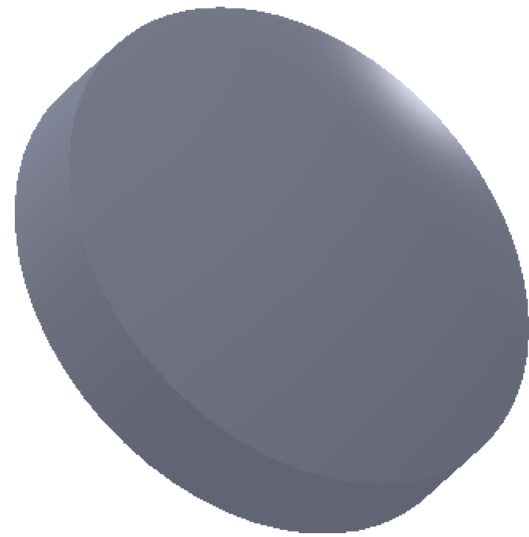

Notes:

- 1) Material: S-LAM60M
- 2) Edge Chamfer: 0.1-0.3 mm.
- 3) AR Coating: <0.5% Reflectivity from 400-650nm ("A" coat) or 620-1080nm ("B" coat), per surface.
- 4) All dimensions in mm unless noted.

1208 Sigma Ct  
 Rockwall, TX 75087  
 Ph: (972) 722-1064  
 Web: www.archeroptx.com



**PROPRIETARY AND CONFIDENTIAL**  
 THE INFORMATION CONTAINED IN THIS DRAWING IS THE SOLE PROPERTY OF ARCHER OPTX, INC. ANY REPRODUCTION IN PART OR AS A WHOLE WITHOUT THE WRITTEN PERMISSION OF ARCHER OPTX, INC IS PROHIBITED.

UNLESS OTHERWISE SPECIFIED:		NAME	DATE	TITLE:  <b>K397</b>
DIMENSIONS ARE IN MM TOLERANCES: FRACTIONAL ± ANGULAR: MACH ± BEND ± TWO PLACE DECIMAL ± THREE PLACE DECIMAL ±		DRAWN		
INTERPRET GEOMETRIC TOLERANCING PER:		CHECKED		
MATERIAL		ENG APPR.		
FINISH		MFG APPR.		
NEXT ASSY	USED ON	Q.A.		SIZE <b>B</b> DWG. NO. REV <b>D</b>
APPLICATION		COMMENTS:		
DO NOT SCALE DRAWING		SCALE: 10:1 WEIGHT:		SHEET 1 OF 1