

REVISIONS			
REV.	DESCRIPTION	DATE	APPROVED
A	Initial	12/8/2015	DF

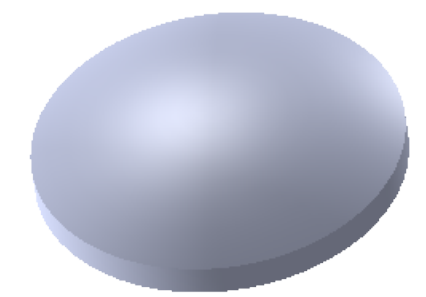
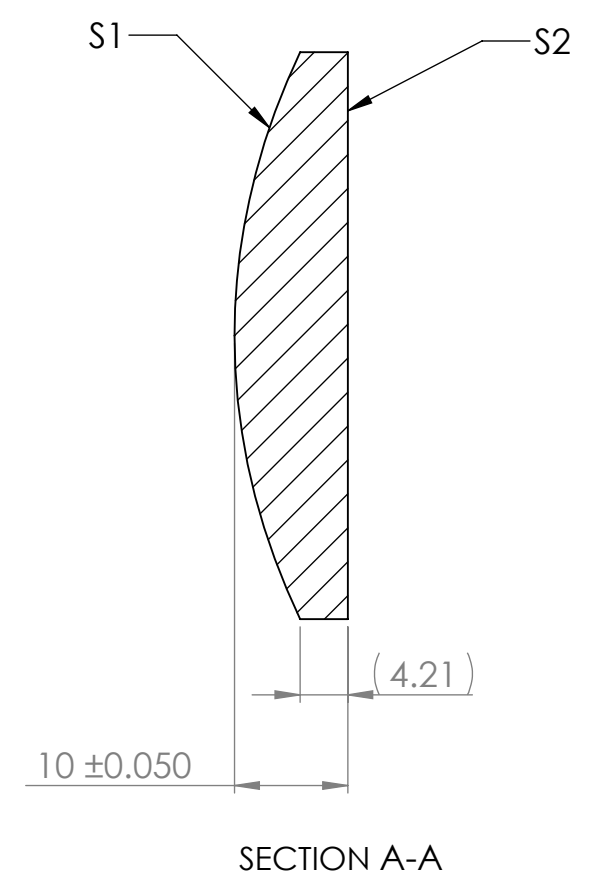
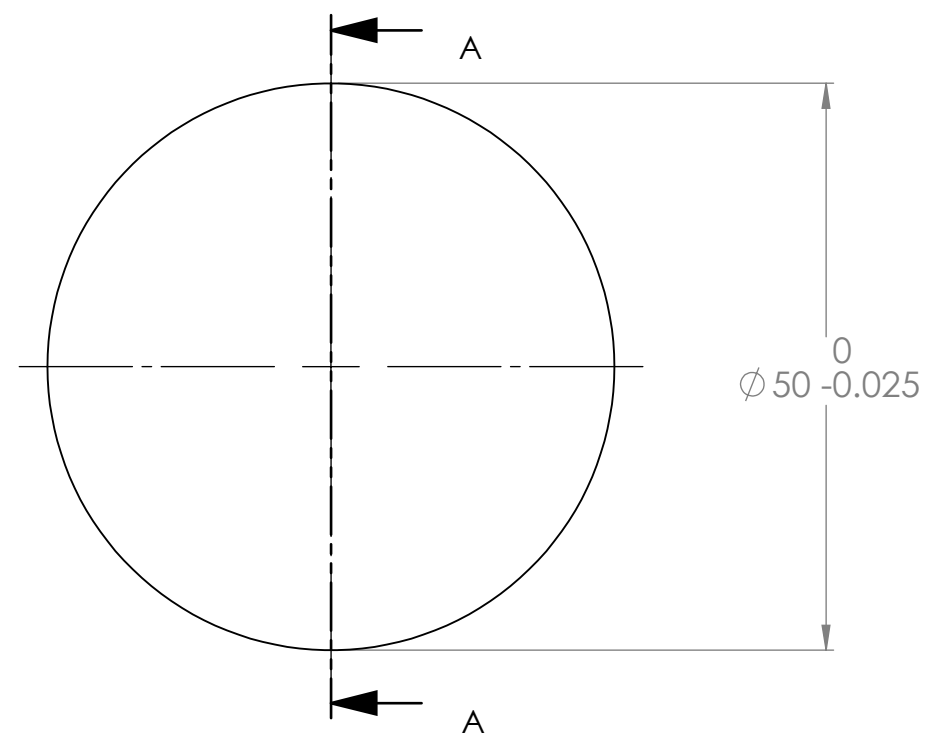

S1 Aspheric Surface:
 Radius: 55.2104 (4 Fringers Power)
 Irregularity: <0.4 micron PV
 Surface Quality: 40/20 SD

S2 Plano Surface:
 Radius: Plano
 Flatness: $\lambda/4$ (< 1 fringe power)
 Surface Quality : 40/20 SD

EFL @ 546nm = 120mm

Notes:
 Material UV Grade Fused Silica
 Clear Aperature 45mm
 Centration/Wedge <3 arcmin
 Custom Coating per Customer Request
 Beval Edges: 0.1-0.3 max max face width at 45 degrees

1208 Sigma CT.
 Rockwall, TX 75087
 Ph: (972) 722-1064
 Web: www.archeroptx.com



PROPRIETARY AND CONFIDENTIAL
 THE INFORMATION CONTAINED IN THIS DRAWING IS THE SOLE PROPERTY OF ARCHER OPTX, INC. ANY REPRODUCTION IN PART OR AS A WHOLE WITHOUT THE WRITTEN PERMISSION OF ARCHER OPTX, INC. IS PROHIBITED.

UNLESS OTHERWISE SPECIFIED:		NAME	DATE	TITLE: Convex Plano Asphere
DIMENSIONS ARE IN MM		DRAWN		
TOLERANCES:		CHECKED		
FRACTIONAL ±		ENG APPR.		
ANGULAR: MACH ± BEND ±		MFG APPR.		
TWO PLACE DECIMAL ±		Q.A.		SIZE DWG. NO. REV B GACP-50-120 A
THREE PLACE DECIMAL ±		COMMENTS:		
INTERPRET GEOMETRIC TOLERANCING PER:				SCALE: 1.5:1 WEIGHT: SHEET 1 OF 1
MATERIAL				
NEXT ASSY	USED ON			
APPLICATION		DO NOT SCALE DRAWING		